

## **MASONRY BUNDS FOR OIL STORAGE TANKS**

## **CIRIA / ENVIRONMENT AGENCIES JOINT GUIDELINES**

*This document provides guidance for the construction of simple, reinforced masonry bunds for oil storage tanks up to 3.5 metres wide and 1200mm high. It is based upon CIRIA Report 163 "Construction of bunds for oil storage tanks" and is jointly produced by the Environment Agency for England and Wales, the Scottish Environment Protection Agency and the Environment and Heritage Service for Northern Ireland, referred to as the agencies. Where circumstances dictate a larger or more complex construction reference should be made to the original report. A similar specification for concrete bunds is also available, free of charge, from the environment agencies. Contact details will be found at the end of this document.*

### *Notes:*

*To be read in conjunction with the enclosed construction drawings. The British Standards referred to in these guidelines are listed in Appendix 1.*

## **1. SITING AND SITE PREPARATION**

### **a. Site investigation**

Avoid sites with:-

- variations in substrata which may give rise to differential settlement
- unstable slopes that may cause slip or other movement
- geological faults, below ground voids or fissures
- deleterious matter present, which may have an adverse effect on construction materials
- a site history which may cause structural problems, e.g. previous mining, made-up ground, underground services, etc.
- low ground bearing pressure (the model designs are based on a permissible ground bearing pressure of not less than 200kN/m<sup>2</sup>).

Note: the siting of a bund is dictated by the location of the primary tank, which may in turn be dictated by the general layout of the facility of which it is part. It may not be possible, therefore, to avoid sites with the characteristics listed above, in which case suitable precautions must be taken. The model drawings assume that the proposed site does not have any of the undesirable features listed above. Where sites with any of the above undesirable features cannot be avoided, specialist advice should be sought.

### **b. Site preparation**

- i. Remove all vegetation and organic top soil from the site to expose the subsoil. Suitable subsoils or substrata include:
  - firm or stiff clay
  - firm or stiff sandy clay
  - boulder clay
  - shale clay (non sulphurous)
  - compact sand or sandy gravel
  - chalk
  - rock.
- ii. Excavate and trim the surface of the excavations to the level surfaces necessary for the formation of wall foundations and the base slab.

**If a larger or more complex construction is required, please refer to CIRIA Report 163 (see back page for details)**

- iii. Soft ground should be excavated and removed, and the formation levelled down to firm ground with a permissible ground bearing pressure of not less than 200kN/m<sup>2</sup>.
- iv. Compact the excavated surfaces using a vibrating roller or vibrating plate compactor.
- v. Protect the prepared formation from the elements prior to construction of base.

## 2. HARDCORE AND BLINDING CONCRETE

Note: Blinding concrete. The British Standard for water retaining structures, BS 8007, requires that at least 75mm of C20 blinding concrete be placed directly over the prepared formation. The structural concrete is then poured onto a polythene slip membrane placed on top of the blinding concrete.

In accordance with BS 8007, this specification requires ground level reinforced concrete slabs and wall foundations to be built on blinding concrete rather than hardcore. Blinding concrete is also required for making up discrepancies in level between the formation and the underside of the structure.

Hardcore should only be used for make up beneath the blinding concrete where the method of placing and compaction gives the hardcore sufficient strength to support the structure without any long-term adverse effect.

- a. Where hardcore is to be used for making up levels, it should conform with Granular Sub Base Type 2, Table 8/3 of the Department of Transport Specification. The following gradation should be used:

BS sieve size	Percentage by mass passing
75mm	100
37.5mm	85 - 100
10mm	45 - 100
5mm	25 - 85
600µm	8 - 45
75µm	0 - 10

Suitable materials include natural sands, gravels, crushed rock and concrete. The soluble sulphate content should be within the DoT specified limits.

- b. The hardcore should be placed in uniform horizontal layers not exceeding 150mm in depth. Each layer must be compacted prior to the placing of the next.
- c. The compaction method should be sufficient to achieve the required permissible bearing pressure of not less than 200kN/m<sup>2</sup>.
- d. Suitable compaction plant includes vibrating rollers having a mass per metre equivalent to 1,300kg with a total weight of 1,000kg, and vibrating plate compactors having an equivalent mass of 1,000kg.
- e. Granular fill in combination with geotextiles may be used to stabilise soft ground. Construction and design techniques are site-specific and expert advice should be obtained before using geotextiles.

## 3. REINFORCED MASONRY WALLS

### a. Reinforced Blockwork to BS 5628

- i. Reinforced blockwork walls may be built off independent reinforced concrete strip foundations or constructed integrally with the reinforced concrete bund floor.

If a larger or more complex construction is required, please refer to CIRIA Report 163 (see back page for details)

- ii. In either case the 'L'-shaped reinforcement bars, which give the blockwork its tensile strength, must be set in the correct positions before the foundation or slab is cast. Longitudinal lacer reinforcement bars are required to maintain the alignment of the 'L'-shaped bars during concrete casting and, where appropriate, to tie the bottom leg of the bar to the mesh reinforcement of the foundations or slab.
- iii. Hollow concrete blocks must comply with BS 6073. Block thickness must be not less than 215mm and net block strength should be not less than  $10\text{N/mm}^2$ .
- iv. The mortar mix for bedding and jointing the blocks shall conform to BS 5628 class (i) and comprise the following proportions by volume:  
1 part of ordinary Portland cement, 1/4 part of hydrated lime, 3 parts sand.
- v. The concrete for infilling the block cores shall be GEN 2 or a mix comprising the following proportions measured by *weight* :  
1 part OPC, 3 parts sand to BS 882, 2 parts coarse aggregate to BS 882.  
The maximum size of the coarse aggregate shall be 10mm. The mix should have a high workability with a concrete slump of 150mm to 200mm. A superplasticiser may be used to help provide the necessary workability.
- vi. The blocks must be laid and bonded so that the cores align vertically and that the completed work is in horizontal and vertical alignment and to the required dimensions. 'U'-shaped flat metal ties (one per core) may be used to bond the block cavities at straight bonded pier positions.
- vii. In order to facilitate proper placing of the infill concrete, the cores of the blocks and the reinforcement must be kept clean of any extraneous or adhered mortar. This can be achieved by placing the joints of the first row of blocks on small concrete block or brick spacers (see drawing no. 16).
- viii. The vertical reinforcement should be fixed prior to laying the blocks.
- ix. Horizontal reinforcement must be placed as the work proceeds.
- x. On completion of the blockwork, the hollow cores should be cleaned out and, when the mortar has hardened sufficiently, filled with concrete. When concrete begins to flow out of the bottom of the wall, the voids between the spacer blocks should be shuttered. The infill concrete should be poured and tamped continuously until all core voids are filled. The cores should be slightly overfilled and the surplus concrete should be trowelled over to form a rounded coping along the top of the wall.
- xi. External surfaces and joints should be finished or prepared as necessary to be compatible with any subsequent surface coatings.
- xii. The wall should not be fully loaded until it has achieved the specified 28-day design strength.
- xiii. Wall Joints. It is extremely difficult to make watertight movement and construction joints in blockwork walls. Joints should therefore be avoided wherever possible, although vertical movement joints are essential to help minimise shrinkage cracking in long walls. Joint component and joint sealant manufacturers should be consulted about suitable products and techniques for forming joints. Hydrostatic pressure limitations on wall joints may dictate the maximum wall height and therefore the bund capacity.  
*Where a masonry wall would be so long (e.g. in multi-tank installations) that a vertical contraction joint would be needed, it is recommended that either more than one bund is constructed (thus negating the need for joints), or that the bund is constructed from reinforced concrete.*

## **b. Reinforced Brickwork to BS 5628**

- i. Reinforced brickwork, either concrete filled cavity or concrete pocket construction, may be founded on individual reinforced concrete strip footings or constructed directly off the reinforced concrete bund floor slab.
- ii. In either case the specified wall reinforcement bars must be set into the concrete foundations and located at the correct positions to provide the reinforcement for

**If a larger or more complex construction is required, please refer to CIRIA Report 163 (see back page for details)**

the walls. Lacer bars are necessary to maintain the position of the reinforcement bars during concrete casting (see 3aii). All wall reinforcement (including horizontal distribution bars in cavity fill construction) must be fixed prior to construction of the wall.

- iii. Clay, solid class B engineering bricks to BS 3921 Table 1 and Table 6, (Class B) shall be used for reinforced brickwork.
- iv. Cavity brickwork should be of bonded stretchers, with the two skins tied together with stainless steel wall ties.
- v. 110mm thick walls and single skin blockwork shall be in stretcher bond: other walls shall be in English bond.
- vi. The mortar mix must conform to BS 5628 class (i) and comprise the following proportions by volume:  
1 part of OPC, 1/4 part of hydrated lime, 3 parts sand.
- vii. The concrete for infilling cavity brickwork should be high workability grade RC30.
- viii. The mix for infilling blockwork cores shall be GEN2 or a mix comprising the following proportions measured by *weight*:  
1 part OPC, 3 parts sand to BS 882, 2 parts coarse aggregate to BS 882.  
The maximum size of the coarse aggregate shall be 10mm. The mix should have a high workability with a concrete slump of 150mm to 200mm. A superplasticiser may be used to help achieve the necessary workability.
- ix. Beds shall be level with joints of uniform thickness and perpend plumb. All beds and joints should be flush and plumb. All bricks should be well wetted prior to laying.
- x. Brickwork should be true, square, and properly bonded and each course levelled round in a uniform manner.
- xi. Reinforcement must be fixed in the correct position and all cavities and pockets kept free from all deleterious matter and extraneous mortar prior to concrete infilling.
- xii. Concrete infill should be uniformly placed and properly compacted in a continuous operation taking care not to displace or damage the brickwork during this operation.
- xiii. Internal surfaces of the walls should be prepared ready to receive any subsequent surface coatings.

#### 4. COATINGS AND SURFACE TREATMENTS

Masonry is inherently more permeable than *in situ* concrete. It is therefore recommended that all internal masonry surfaces are rendered with at least 19 mm of sharp sand/OPC 3:1 mix applied in two coats. Surfaces should be properly prepared and wetted prior to application. Special attention should be given to the junction of the wall and floor slab. A mastic sealant is recommended at the junction. Grooves should be cut in the concrete ready to receive the finished coatings. The second render coat should be applied so that joints in work areas do not coincide with joints in the first coat.

##### **Appendix 1 List of British Standards referred to in this specification**

BS 8007:1987 *Design of concrete structures for retaining aqueous liquids*

BS 882: 1992 *Specification for aggregates from natural sources for concrete*

BS 5628:Part 3: 1985 *Use of masonry*

BS 6073:1981 *Precast concrete masonry units*

BS 3921:1985 *Clay bricks*

If a larger or more complex construction is required, please refer to CIRIA Report 163 (see back page for details)

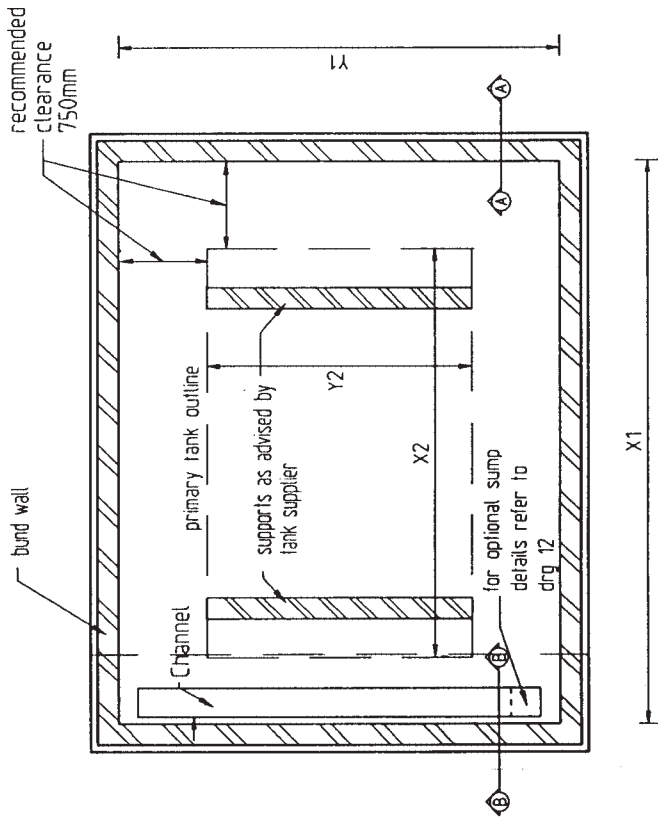

Brickwork bund up to 3.5m wide where ground not susceptible to frost heave

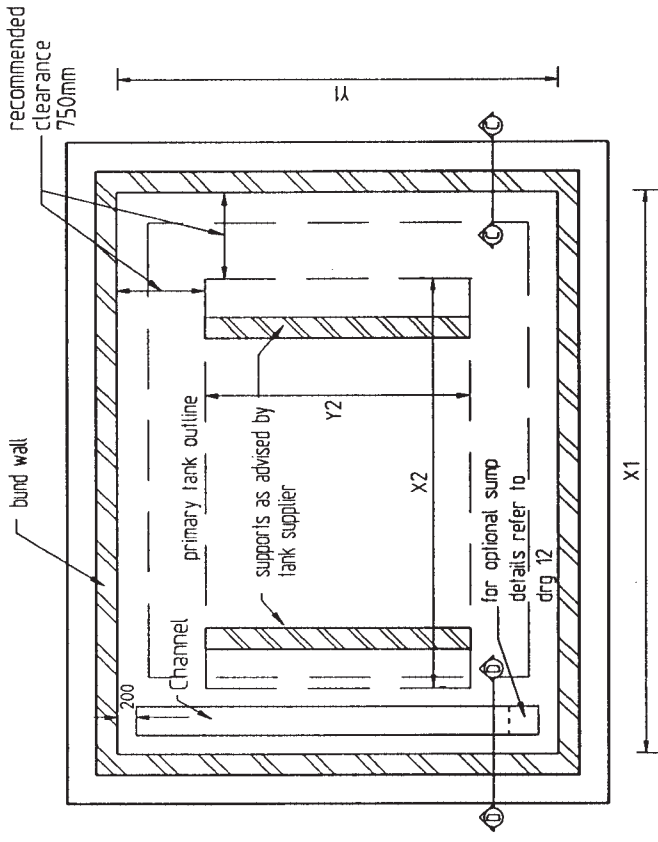

Brickwork bund from 3.5m to 7m wide or where ground susceptible to frost heave

Calculation of length / width of bund

X1 (internal length of bund) = X2 (length or diam. of primary tank) + 1.5 m  
 Y1 (internal length of bund) = Y2 (width or diam. of primary tank) + 1.5 m

Calculation of height of bund wall

(a) Method 1 - 110% rule (see Section 3.2 of report)

height of bund wall =  $[1.1 \times \text{primary tank volume} / (X1 \times Y1)] + [\text{volume of tank supports} / (X1 \times Y1)]$

(b) Method 2 - alternative method (see Section 3.3 of report)

height of bund wall =  $(\text{primary tank volume} / (X1 \times Y1)) + [\text{volume of tank supports} / (X1 \times Y1)] + \text{freeboard}$

Freeboard to be allowed for rainwater, fire fighting agents and dynamic effects as appropriate and as defined in Section 3.3 of report.

This drawing to be read in conjunction with drawing Nos 9, 11 and specification

Drawing Title	Reinforced brickwork bund: general arrangement.
drg No	8

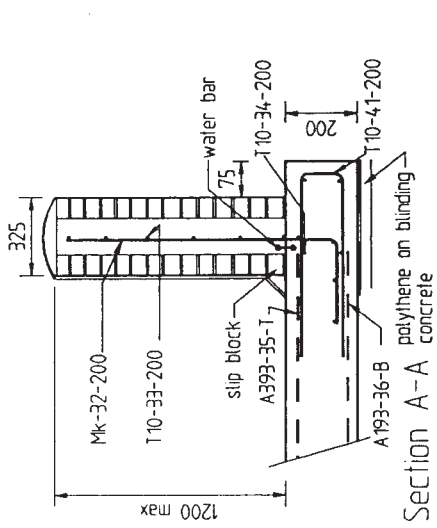

Section A-A

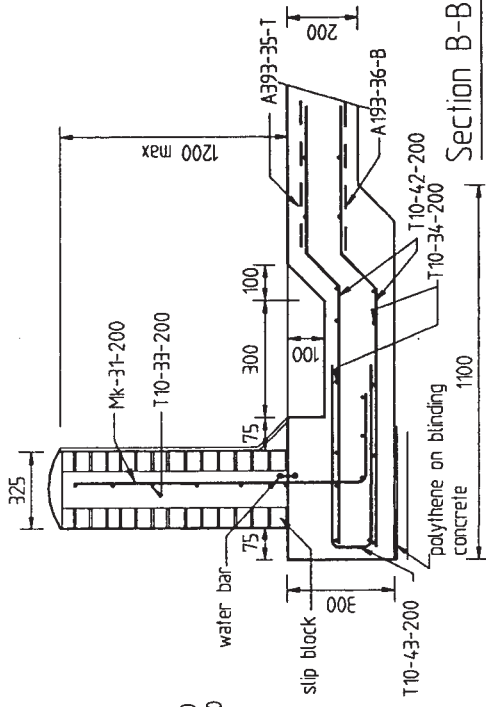

Section B-B

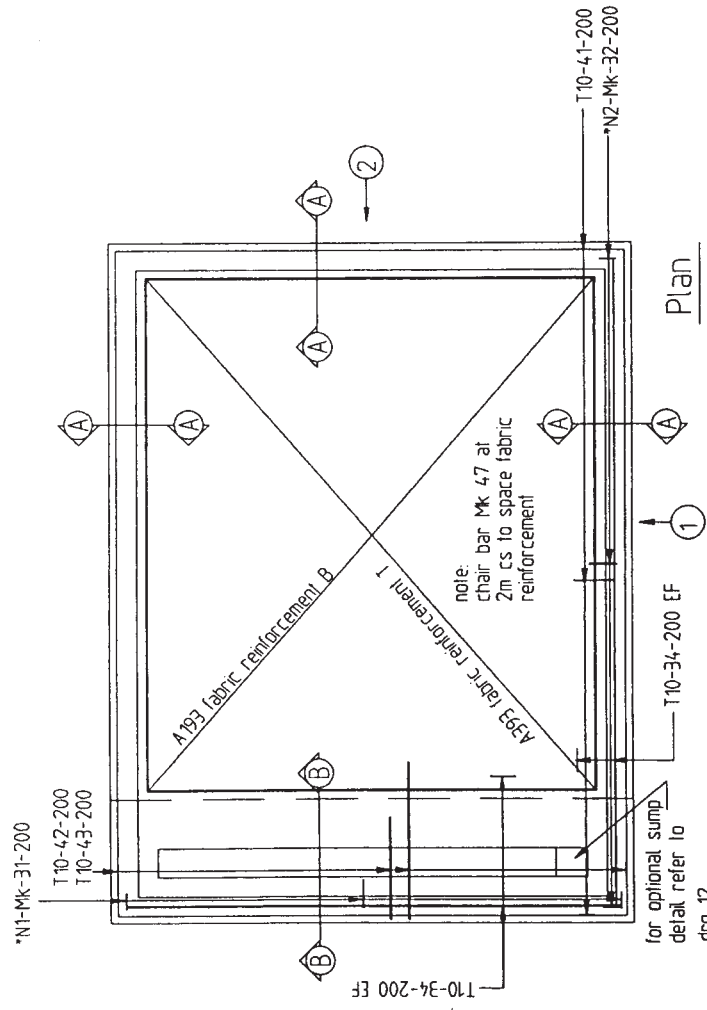

Plan

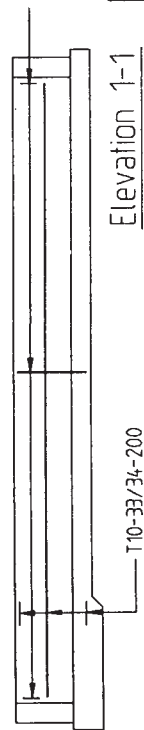

Elevation 1-1

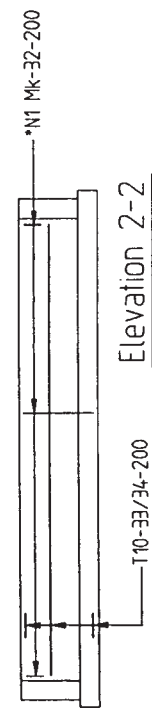

Elevation 2-2

member	bar Mk	type/size/cs	shape code	length	A	B	C	D
wall/founds	31	T10<900ht&T12>900ht	37	H+580	H+180	425		
wall/founds	32	T10<900ht&T12>900ht	37	H+480	H+80	425		
wall	33	T10-200	20	distribution to suit W or L				
wall corner	39	T10-200	37	1175	600	600		
wall corner	40	T10	81	820	210	60		
floor/founds	34	T10-200	20	distribution to suit W+L or L+L				
floor/founds	35	A393 fabric Top	-					
floor/founds	36	A193 fabric Bottom	-					
floor/founds	41	T10-200	38	1530	750	80	750	
floor/founds	42	T10-200	41	1165+1	450	140	575+1	100
floor/founds	43	T10-200	38	930	450	80	450	
floor/founds	47	R10-2000	83	630	250	80	150	150

\* number of bars (N1/N2) = (wall length / 200) + 1  
 H = height of bund wall  
 W = Y1 + thickness of bund wall + 50mm  
 L = X1 + thickness of bund wall + 50mm

l = thickness of bund wall  
 Y1 = internal width of bund  
 X1 = internal length of bund

This drawing to be read in conjunction with drawing No 8, 11 and specification

Drawing title  
**Reinforced brickwork bund:**  
 up to 3.5m wide and  
 1200mm high.

drg No **9**

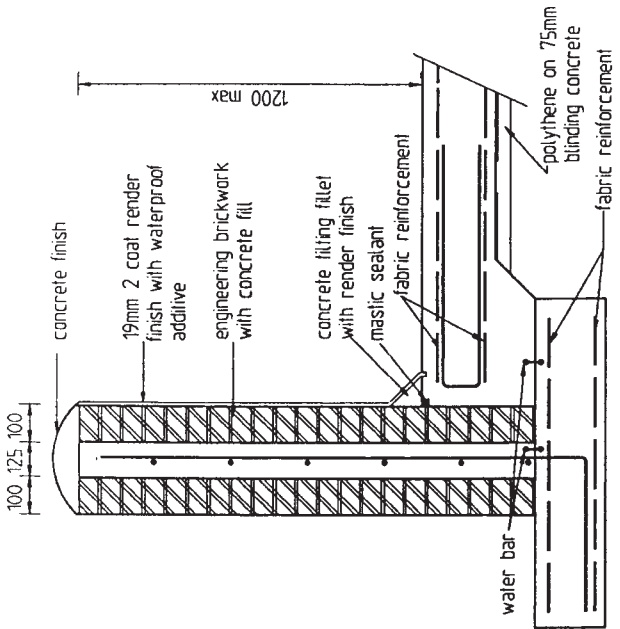

Details for brickwork bund walls.  
(walls built off slab refer to drg 9)

**CONSTRUCTION NOTES:**

- it is important to ensure that the reinforcement is correctly positioned, the cavity is clear and all surfaces are properly prepared prior to filling the cavity with concrete. Special care is needed where water bars are provided
- it is recommended that the brickwork incorporates sufficient openings, particularly at foundation level, to facilitate cleaning of the cavity and to allow for preparation of the concrete surface prior to cavity filling
- during placing of the cavity fill the access holes should be shuttered once it has been observed that the concrete is properly filling the cavity voids and that the reinforcement has not been displaced
- the concrete must be properly compacted to achieve the required strength and impermeability. Care must be taken to avoid damaging the brickwork and temporary supports may be necessary during casting
- the shuttering, and any temporary supports to the brickwork, must not be moved until at least 12 hours after casting.

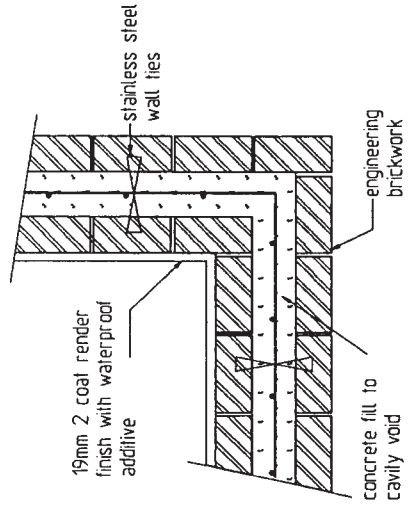

Corner plan

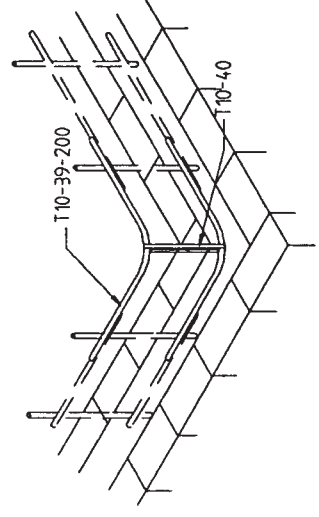

Corner reinforcement detail

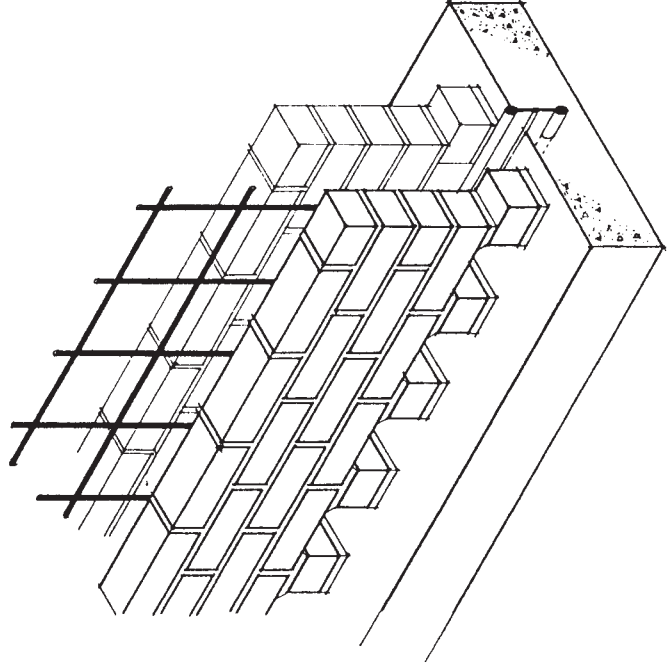

This drawing to be read in conjunction with drawing No. 8, 9 and specification

Drawing Title  
Reinforced brickwork bund:  
construction details

drg No 11

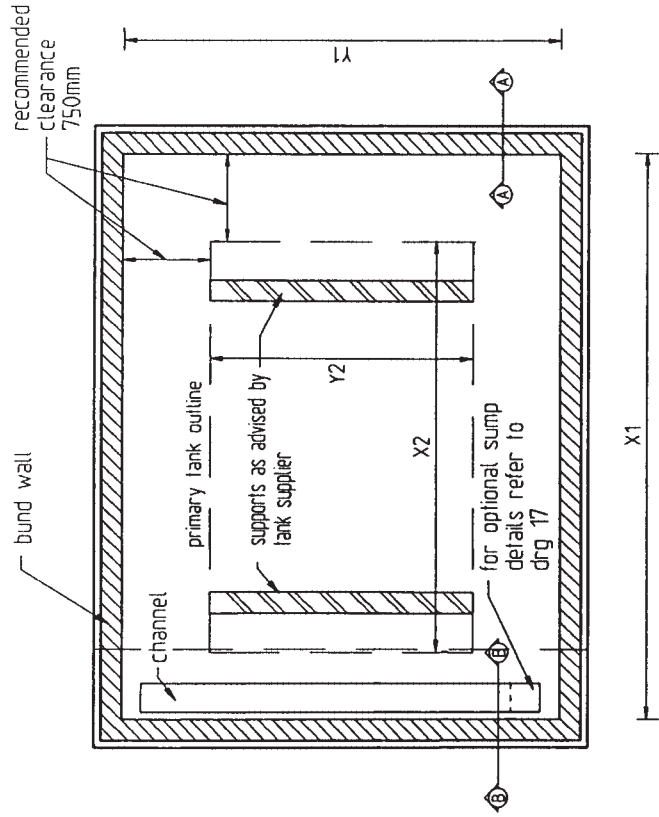

Reinforced blockwork bund up to 3.5m wide where  
ground not susceptible to frost heave

Calculation of length / width of bund

X1 (internal length of bund) = X2 (length or diam. of primary tank) + 15 m  
Y1 (internal length of bund) = Y2 (width or diam. of primary tank) + 15 m

Calculation of height of bund wall

(a) Method 1 - 110% rule (see Section 32 of report)

height of bund wall =  $[1.1 \times \text{primary tank volume} / (X1 \times Y1)] + [\text{volume of tank supports} / (X1 \times Y1)]$

(b) Method 2 - alternative method (see Section 3.3 of report)

height of bund wall =  $[\text{primary tank volume} / (X1 \times Y1)] + [\text{volume of tank supports} / (X1 \times Y1)] + \text{freeboard}$

Freeboard to be allowed for rainwater, fire fighting agents and dynamic effects as appropriate and as defined in Section 3.3 of report.

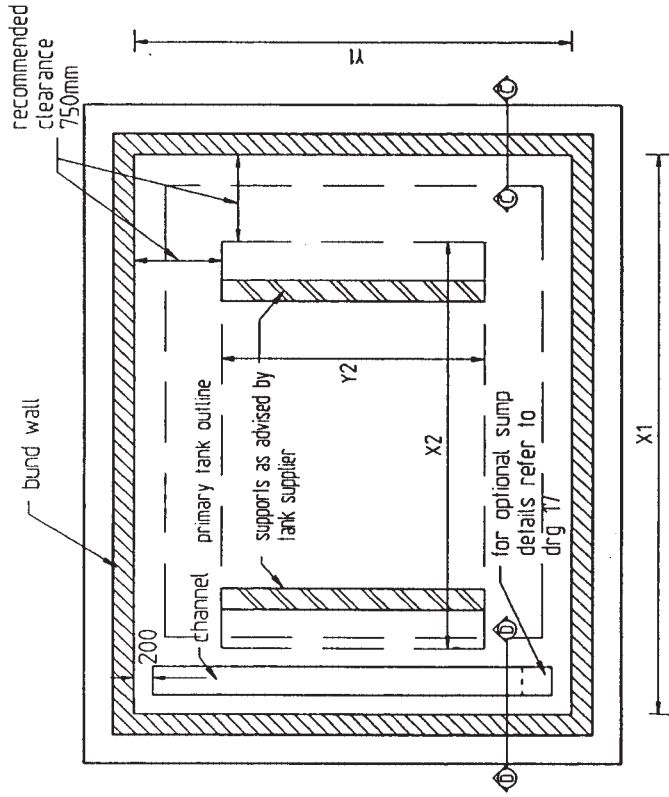

Reinforced blockwork bund from 3.5m to 7m wide or where  
ground susceptible to frost heave

This drawing to be read in conjunction with drawing No 14, 16, 17 and specification

Drawing Title

Reinforced blockwork bund:  
general arrangement.

drg No

13



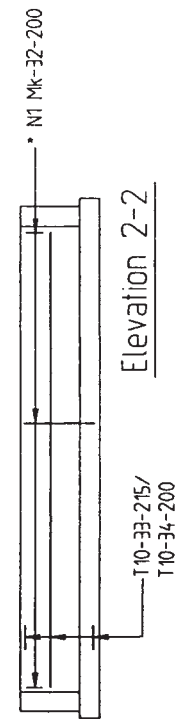
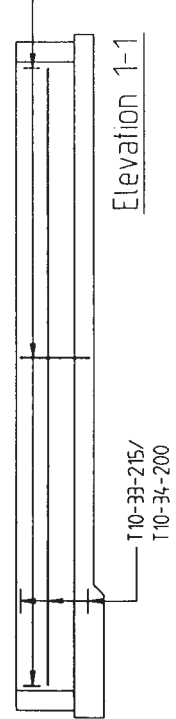
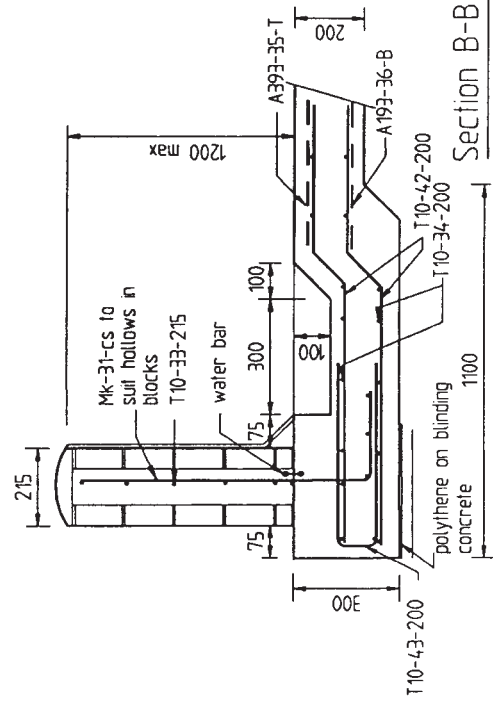
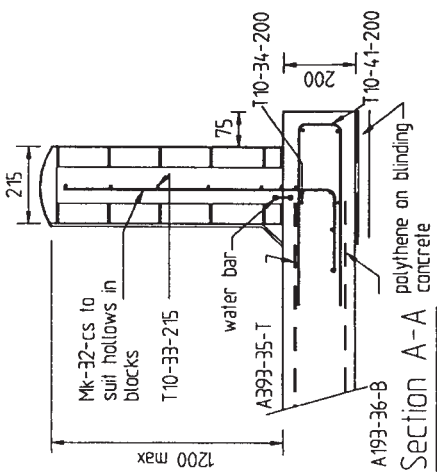
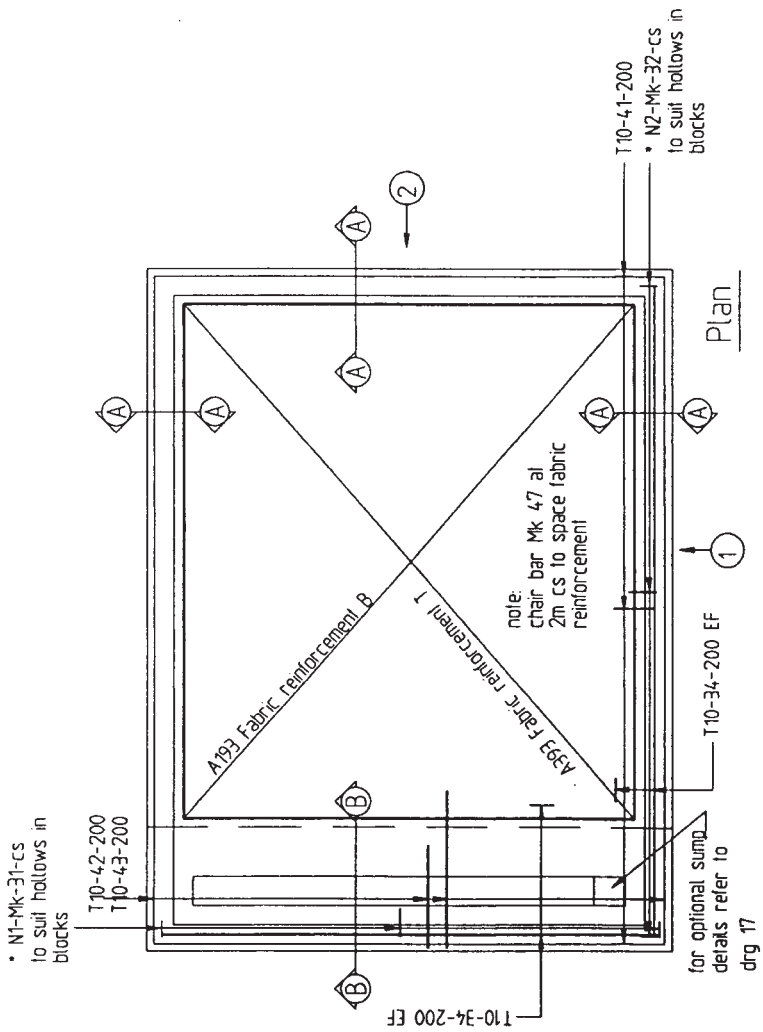

member	bar Mk	type/size/cs	shape length	A	B	C	D
wall/founds	31	T10<900ht&T12>900ht	37 H+580	H+180	425		
wall/founds	32	T10<900ht&T12>900ht	37 H+480	H+80	425		
wall	33	T10-215	20 distribution to suit W or L				
wall corner	39	T10-215	37 1175	600	600		
floor/founds	34	T10-215	20 distribution to suit W+1 or L+1				
floor/founds	35	A393 fabric Top	-				
floor/founds	36	A193 fabric Bottom	-				
floor/founds	41	T10-200	38 1530	750	80	750	
floor/founds	42	T10-200	41 1165+1	450	140	575+1	100
floor/founds	43	T10-200	38 930	450	80	450	
floor/founds	47	R10-2000	83 630	250	80	150	150

\* number of bars (N1N2) = (wall length / 200) + 1  
H = height of bund wall  
W = Y1 + thickness of bund wall + 50mm  
L = X1 + thickness of bund wall + 50mm  
I = thickness of bund wall  
Y1 = internal width of bund  
X1 = internal length of bund

This drawing to be read in conjunction with drawing No 13, 16, 17 and specification

Drawing Title  
**Reinforced blockwork bund:**  
up to 3.5m wide and  
1200mm high.

drg No **14**

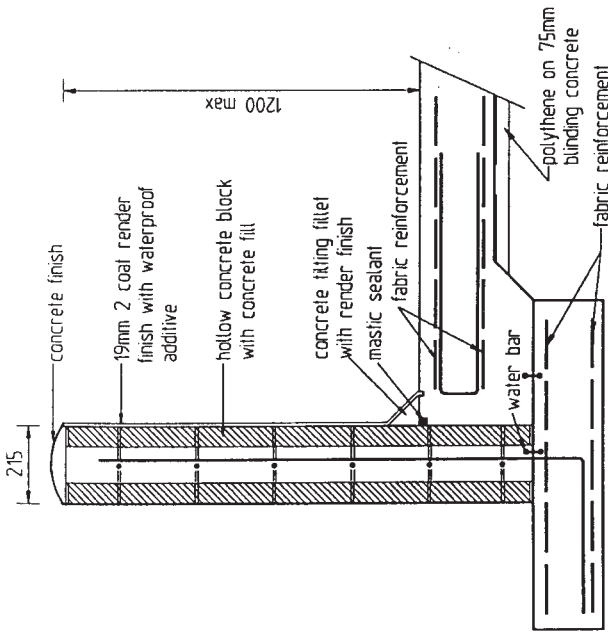

Blockwork bund wall built off strip foundation

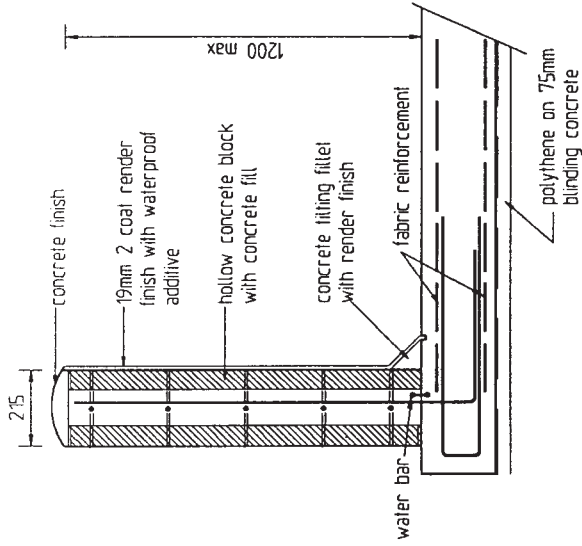

Blockwork bund wall built off slab.

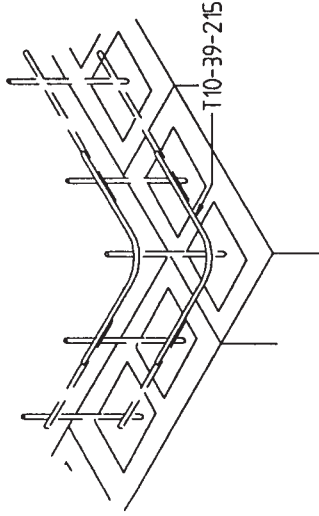

Corner reinforcement detail

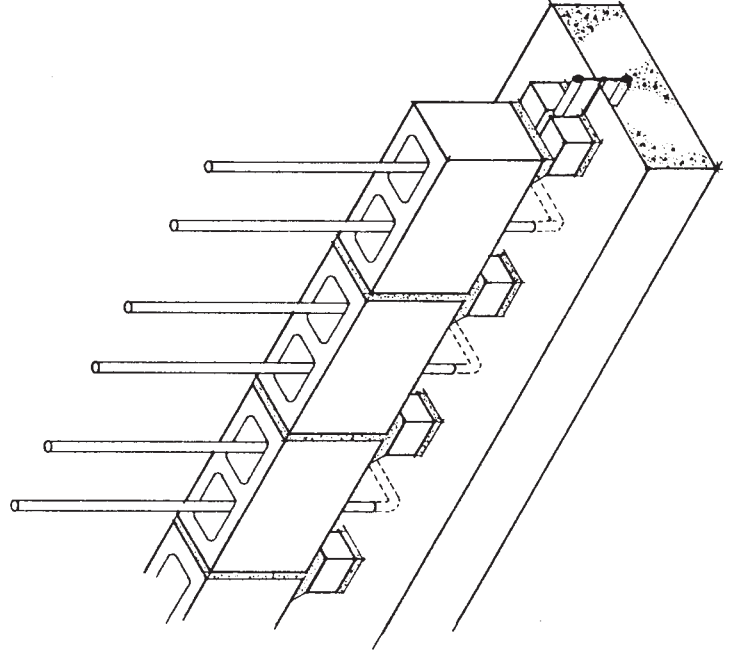

**CONSTRUCTION NOTES:**

In a reinforced blockwork wall it is important to ensure that the reinforcement is correctly positioned and all voids in the blocks are filled with concrete. To achieve this the following procedure is recommended :

- position starter bars in foundation to line up with block cavities. It is important that reinforcement bars are positioned precisely as shown on the drawings.
- pour foundation concrete and allow to cure
- start construction of wall by positioning concrete (or other suitable material) slip blocks, so that the centre-line of each slip block coincides with the vertical joints in the blockwork. The slip block spacers form part of the wall and should be mortared in position
- place first course of blocks over bars and bed in mortar. Proceed similarly for next three courses, positioning the vertical and horizontal reinforcement as detailed.
- before mortar has fully hardened, clean out hollows in blocks, removing all projecting nibs of mortar etc. This can be achieved using a length of reinforcing bar.
- clear away debris at base of wall, by way of the gaps created by the slip blocks
- position remaining reinforcement, and fill hollows with high-workability concrete mix ( see specification ). When concrete appears at bottom of wall indicating that it is flowing properly in the hollows, position and secure formwork stop-ends to retain concrete.
- continue pouring concrete until all hollows/voids are filled, using a reinforcing bar or timber batten to compact it and to ensure there are no air pockets
- allow at less 12 hours before removing formwork

This drawing to be read in conjunction with drawing No 13 , 14 , 17 and specification

Drawing Title  
Reinforced blockwork bund:  
construction details

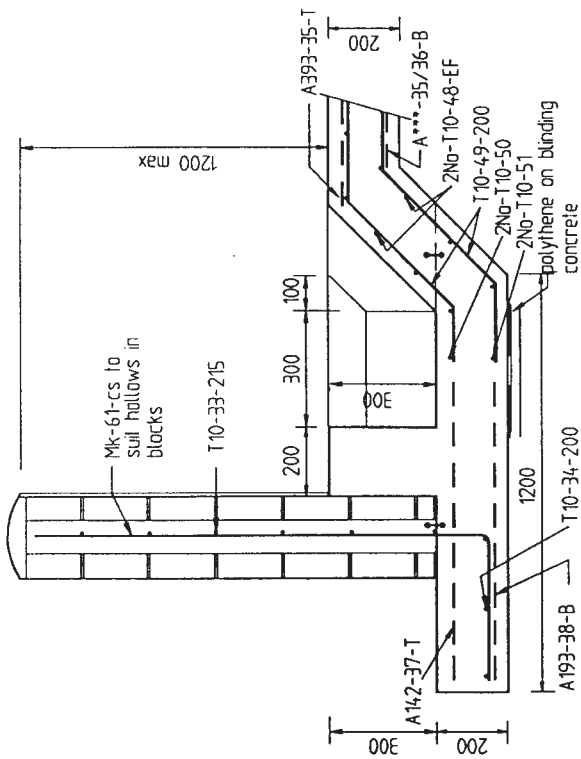

Section A-A sump detail for bund construction to drg 15

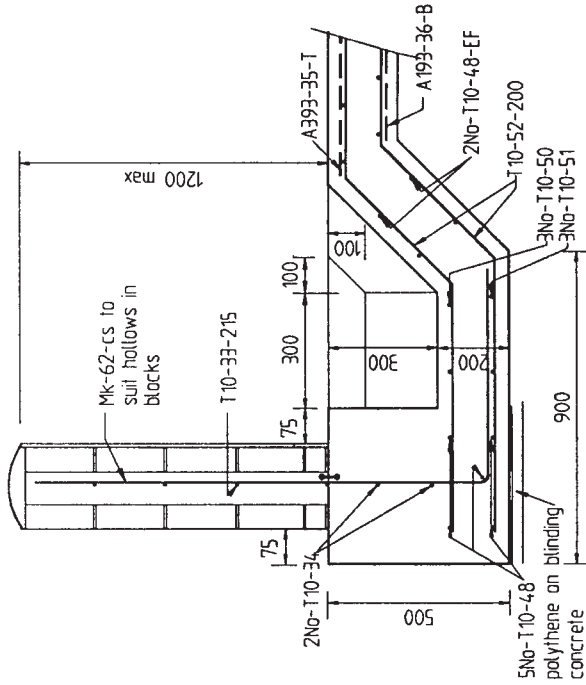

Section A-A sump detail for bund construction to drg 14

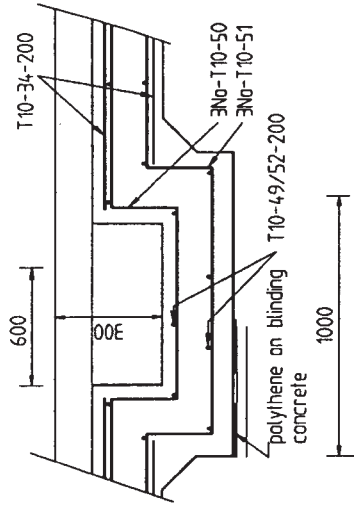

Typical Section B-B

member	bar Mk	type/size/cs	shape code	length	A	B	C	D	E
Section A-A sump detail for bund construction to drg 15									
wall/founds	61	T10<9008	T12<900	37	H+800	H+400	425		
wall	33	T10-200		20	distribution to suit W				
foundations	34	T10-200		20	distribution to suit W+1				
foundations	48	T10-200		20	distribution to suit Y5-80mm				
foundations	49	T10-200		41	1025	150	425	450	
foundations	50	T10-200		53	Y5+1320	450	200	Y5+120	200
foundations	51	T10-200		53	Y5+1520	450	200	Y5+320	200
foundations	37	A142 fabric	T+B	-					
foundations	38	A193 fabric	T+B	-					
Section A-A sump detail for bund construction to drg 14									
wall/founds	62	T10<9008	T12<900	37	H+800	H+400	425		
wall	33	T10-200		20	distribution to suit W				
foundations	34	T10-200		20	distribution to suit W+1				
foundations	48	T10-200		20	distribution to suit Y5-80mm				
foundations	50	T10-200		53	Y5+1320	450	200	Y5+120	200
foundations	51	T10-200		53	Y5+1520	450	200	Y5+320	200
foundations	52	T10-200		41	1125	850	425	450	
foundations	35	A393 fabric	T+B	-					
foundations	36	A193 fabric	T+B	-					

H = height of bund wall  
W = Y1 + thickness of bund wall + 50mm  
L = X1 + thickness of bund wall + 50mm  
t = thickness of bund wall  
Y1 = internal width of bund  
X1 = internal length of bund

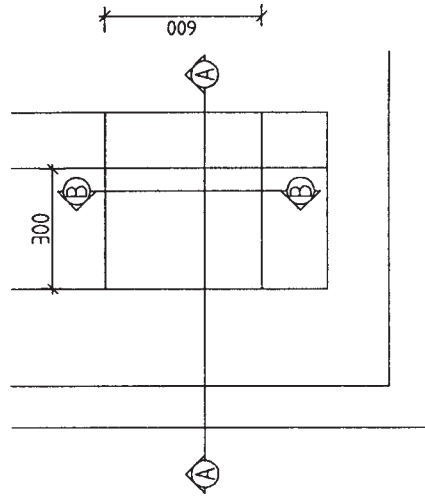

Plan of Sump

Drawing Title  
Reinforcement details for optional sump in bund with blockwork walls  
drg No. 17



For 40 years CIRIA - the Construction Industry Research and Information Association - has managed collaborative research and produced information aimed at providing best practice solutions to industry problems. CIRIA stimulates the exchange of experience across the industry and its clients, and has an established reputation for practical, high quality information. Through networking and the dissemination of publications and newsletters, CIRIA seeks to improve the performance of all concerned with construction and the environment.

For further information please contact CIRIA by:

Post: 6, Storey's Gate, Westminster, London SW1P 3AU  
Tel: 020 7222 8891 (General Enquiries) 020 7799 3243 (Publications)  
Fax: 020 7222 1708  
e-mail: [enquiries@ciria.org.uk](mailto:enquiries@ciria.org.uk)

Further details are available on CIRIA's Web site: [www.ciria.org.uk](http://www.ciria.org.uk)

CIRIA Report 163 "Construction of bunds for oil storage tanks"  
ISBN 0 86017 468 9 Available from CIRIA, price £18

All the Agencies' pollution prevention guidance notes are available on the web sites listed below.

#### ENVIRONMENT AGENCY

##### HEAD OFFICE

Rio House, Waterside Drive, Aztec West  
Almondsbury, Bristol BS32 4UD.  
Tel: 01454 624 400 Fax: 01454 624 409  
World Wide Web: <http://www.environment-agency.gov.uk>

##### REGIONAL OFFICES

###### ANGLIAN

Kingfisher House  
Goldhay Way  
Orton Goldhay  
Peterborough PE2 5ZR  
Tel: 01733 371 811  
Fax: 01733 231 840

###### MIDLANDS

Sapphire East  
550 Streetsbrook Road  
Solihull B91 1QT  
Tel: 0121 711 2324  
Fax: 0121 711 5824

###### NORTH EAST

Rivers House  
21 Park Square South  
Leeds LS1 2QG  
Tel: 0113 244 0191  
Fax: 0113 246 1889

###### NORTH WEST

Richard Fairclough House  
Knutsford Road  
Warrington WA4 1HG  
Tel: 01925 653 999  
Fax: 01925 415 961

###### SOUTHERN

Guildbourne House  
Chatsworth Road  
Worthing  
West Sussex BN11 1LD  
Tel: 01903 832 000  
Fax: 01903 821 832

###### SOUTH WEST

Manley House  
Kestrel Way  
Exeter EX2 7LQ  
Tel: 01392 444 000  
Fax: 01392 444 238

###### THAMES

Kings Meadow House  
Kings Meadow Road  
Reading RG1 8DQ  
Tel: 0118 953 5000  
Fax: 0118 950 0388

###### WELSH

Rivers House  
St Mellons Business Park  
St Mellons  
Cardiff CF3 0EY  
Tel: 029 2077 0088  
Fax: 029 2079 8555

#### SCOTTISH ENVIRONMENT PROTECTION AGENCY

##### HEAD OFFICE

Erskine Court  
The Castle Business Park  
Stirling FK9 4TR  
Tel: 01786 457 700  
Fax: 01786 446 885  
World Wide Web: <http://www.sepa.org.uk>

##### REGIONAL OFFICES

###### NORTH REGION HQ

Graesser House  
Fodderty Way  
Dingwall Business Park  
Dingwall IV15 9XB  
Tel: 01349 862 021  
Fax: 01349 863 987

###### WEST REGION HQ

SEPA West  
5 Redwood Crescent  
Peel Park  
East Kilbride G74 5PP  
Tel: 01355 574 200  
Fax: 01355 574 688

###### EAST REGION HQ

Clearwater House  
Heriot-Watt Research Park  
Avenue North  
Riccarton  
Edinburgh EH14 4AP  
Tel: 0131 449 7296  
Fax: 0131 449 7277

#### ENVIRONMENT & HERITAGE SERVICE

Calvert House,  
23 Castle Place,  
Belfast  
BT1 1FY  
Tel: 028 9025 4868  
Fax: 028 9025 4777

The 24-hour emergency hotline number for reporting all environmental incidents relating to air, land and water in England, Wales, Scotland and Northern Ireland.

**EMERGENCY HOTLINE**

**0800 80 70 60**



**ENVIRONMENT AGENCY**



**ENVIRONMENT AND HERITAGE SERVICE**

**ENVIRONMENTAL ALLIANCE – WORKING TOGETHER**